

PURPOSE-BUILT MINING EQUIPMENT



GETMAN SERIES 10 TELEHANDLER machines are now part of the company's comprehensive fleet of utility equipment. With a broad range of reach and lift capabilities, telehandlers meet the underground mining sector's ongoing need for material transport.

Getman Telehandlers are defined by their rugged design and reliability. They feature superior machine and boom stability, are flexible and agile, and offer good visibility for greater safety. With appropriate engine options

and enhancements to improve operator comfort and efficiency, the telehandler is an appealing complement to Getman's fleet of utility and purpose driven products.

The Getman Telehandler Series delivers the quality and durability expected with the Getman brand, all backed by a wide-reaching support and service network that is critical to sustaining productive underground mining operations.



TECHNICAL SPECIFICATIONS

ENGINE

- Tier IV 87 kW (117 HP) Cummins® turbo diesel with DOC muffler
- Optional MSHA/CANMET approved Tier 3 89 kW (120 HP) Deutz® engine
- 113 L (30 gal) fuel tank

TRANSMISSION

- Dana® VDT12000 Series transmission
- Three speed Powershift, forward and reverse
- 4-wheel drive

AXLES

- Dana 212 Series: 45% limited slip front differential

TIRES

- 16 ply, G2 tread air-fill standard
 - › 13.00 x 24

BRAKE SYSTEM

- Oil-immersed inboard disc service brakes
- Integral front SAHR park brake

STEERING

- 4 wheel
- 2 wheel
- Crab steer

BOOM

- 3-section, slide pad
- Automatic fork leveling without slave cylinder

HYDRAULIC SYSTEM

- Pressure comp, axial piston pump
- Fully proportional functions
- Auxiliary boom tip hydraulics
- Quick disconnect for attachments
- Single joystick controls, pilot operated

FRAME

- 20° of leveling (10° right and left)
- Rear axle stabilization system

OPERATOR COMPARTMENT

- Adjustable suspension seat with seat belt
- Single multifunction hydraulic joystick
- Analog/LCD gauge cluster
- Split door design
- Flat, bolt-in glass
- Lockable storage area under seat

GENERAL EQUIPMENT

- 1829 mm (72 in) carriage
- Standard 1219 mm (48 in) fork tines
- High output LED lighting package
- Sling hook

DIMENSIONS

- Overall Height - 272 cm (8 ft 11 in) boom down
- Fork Carriage - 183cm (72 in) standard
- Ground Clearance - 46 cm (18 in)
- Overall Length - 699 cm (22 ft 11 in) to fork frame
- Overall Width - 259 cm (8 ft 6 in)
- Pallet Forks - 5.7 x 10 x 122 cm (2.25 x 4 x 48 in) standard
- Approximate Operating Weight - 12,134 kg (26,750 lbs)

PERFORMANCE

- Maximum Load Capacity - 4,536 kg (10,000 lbs)
- Maximum Lift Height - 1,415 cm (46 ft 5 in)
- Landing Height - 1,280 cm (42 ft)
- Maximum Forward Reach - 915 cm (30 ft) at 24 in LC
- Below Grade Reach - 97 cm (3 ft 2 in)
- Maximum Travel Speed - 24.5 km/h (15.2 mph)
- Turning Radius - 437cm (14 ft 4 in)
- Drawbar Pull (GVW) - 11,861 kg (26,150 lbs)

AVAILABLE ATTACHMENTS

- Pallet, lumber, or block forks
- Side tilt carriage (+/- 10°)
- Truss boom

OPTIONAL

- Premium gauge cluster with 178 mm (7 in) digital display
- Rear-view camera system
- Solid or foam filled tires
- Various tire tread options
- Enclosed cab, HWD (A/C available)
- Electrical to boom tip
- 1829 mm (72 in) fork tines
- Bolt-on rear pintle hitch

LIFT PERFORMANCE

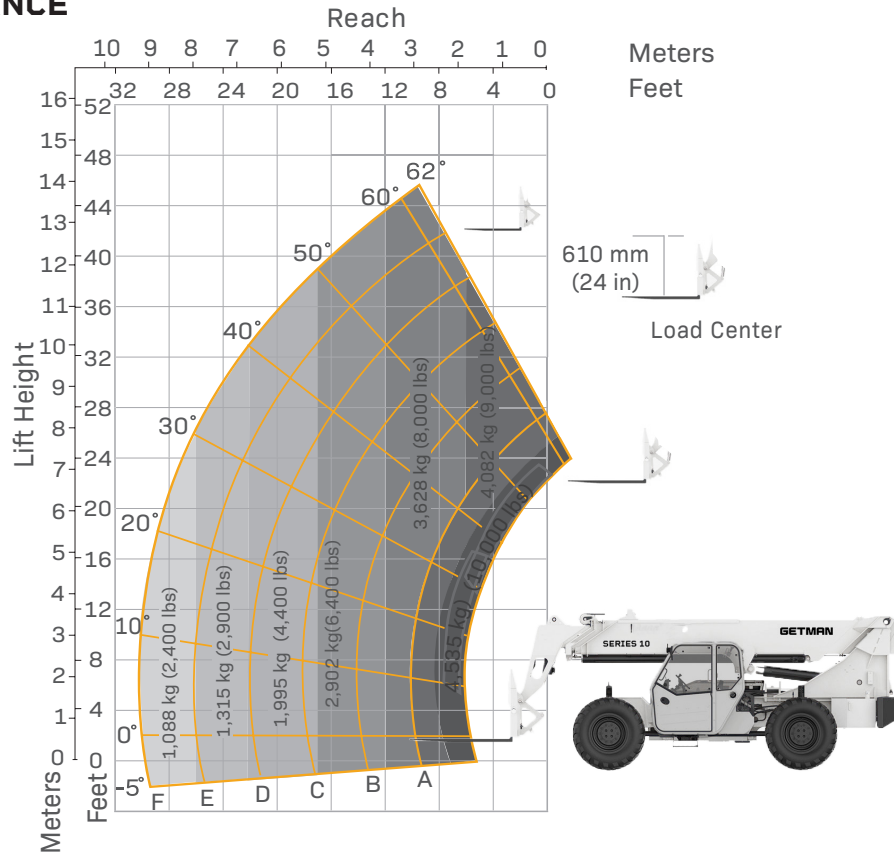

TURNING RADIUS

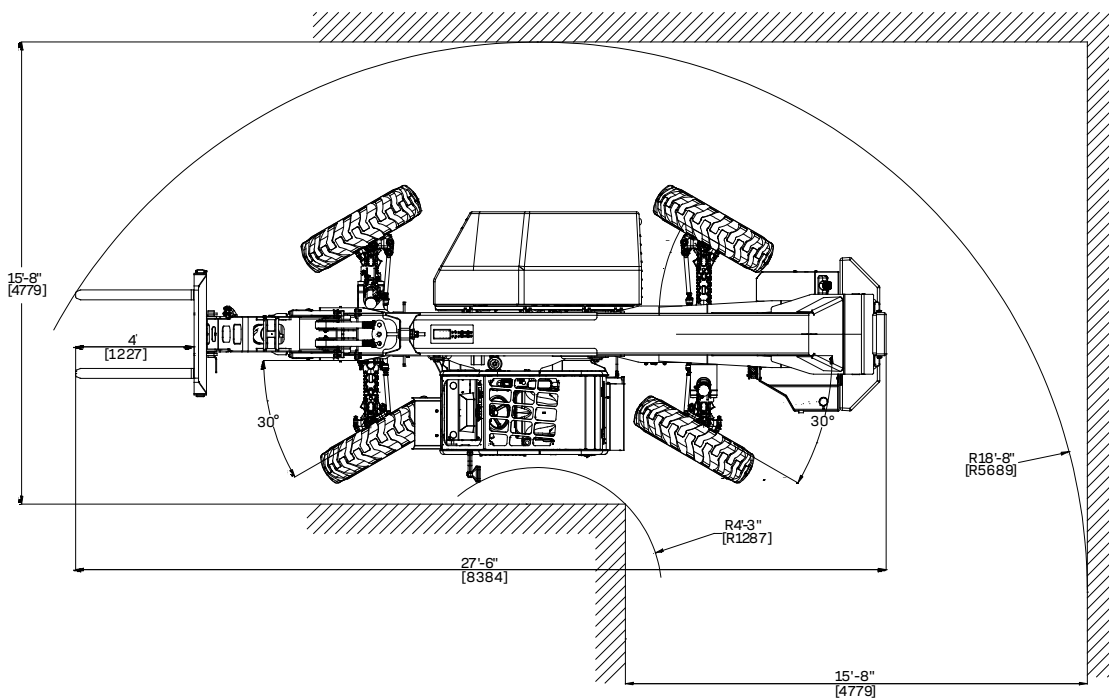



ABOUT GETMAN CORPORATION

Getman Corporation is a global supplier of mobile equipment to the mining industry, offering customer-specific solutions to underground mines in the production and production support classes of equipment. All Getman equipment is designed with extensive research and development and is supported by over 65 years of experience in serving the underground mining industry.

Through our network of distributors we sell and support our products on six continents, offering exceptional product solutions and following up with world class aftermarket support. At Getman Corporation, designing and building machines for the underground mining industry is what we do. We take pride in being the preferred supplier of underground production and production support equipment to miners globally by offering customer-specific, value-driven and long-lasting solutions.

For more information contact your Getman distributor or email us at info@getman.com, or visit our website at getman.com.

For parts or service support, email us at parts@getman.com or service@getman.com.

Getman Corporation assembled this datasheet with the intention of passing along the most accurate information possible, however this document is not binding in any way and is considered informational only. All values stated herein are theoretical in nature. All orders are accepted based on the terms and conditions set forth in the individual purchase or sales agreement. Getman reserves the right to update the specification herein at any time and without further notification.

Pictured machines in this document may contain optional and additional equipment.

GETMAN

GETMAN CORPORATION
59750 34th Avenue
Bangor, MI 49013 USA

Tel +1 (269) 427-5611
info@getman.com
getman.com