

Machine Length	10217 mm	402 in
Wheelbase Length	3569 mm	140 in
Ground Clearance	314 mm	12 in
Machine Height (canopy)	2660 mm	105 in

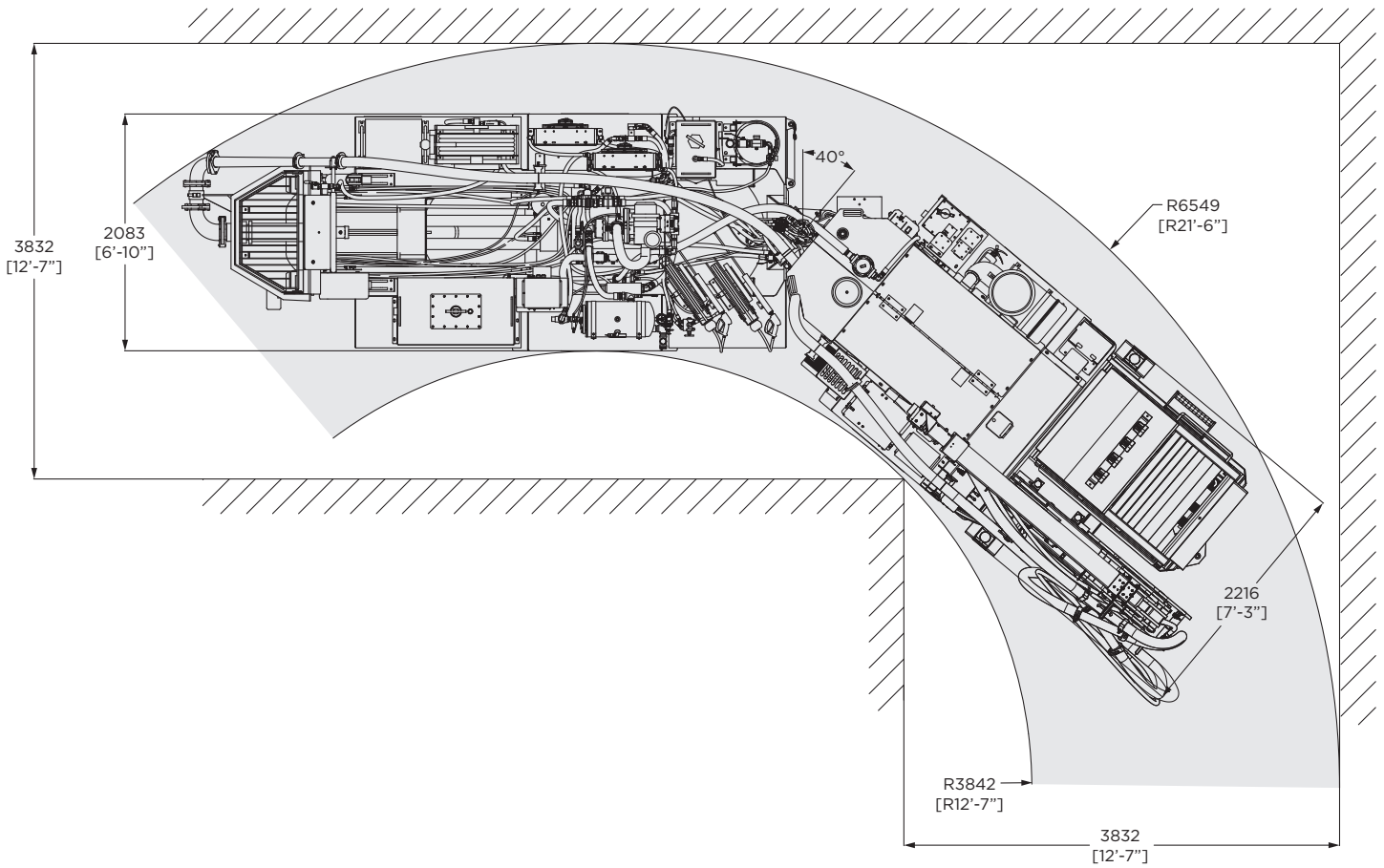

Machine Width	2216 mm	87 in
Inner Turning Radius	3542 mm	151 in
Outer Turning Radius	6549 mm	258 in

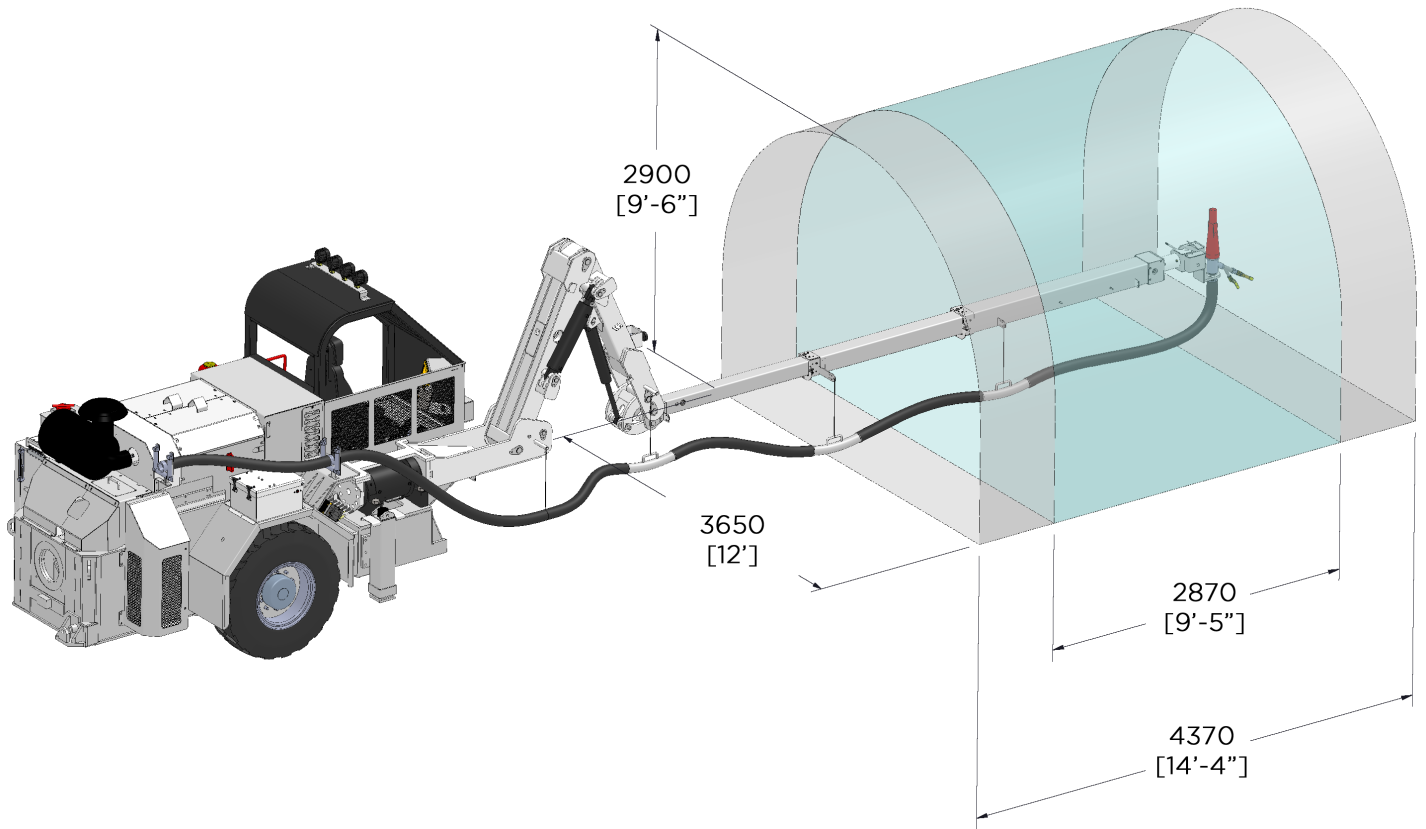

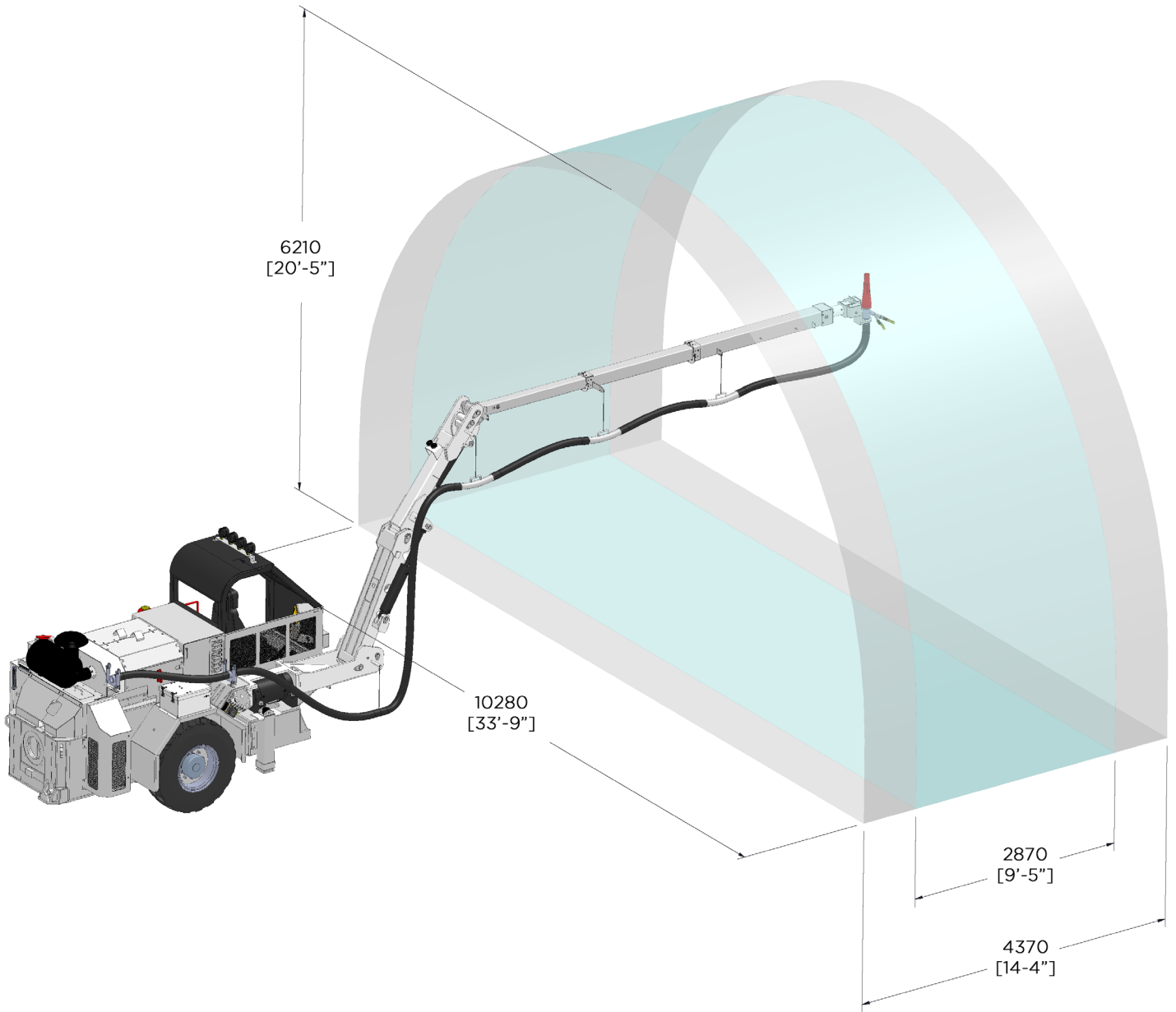

*This document shall be considered informational only. All values stated herein are theoretical in nature. Getman reserves the right to make changes to the specification herein at any time and without further notification.*