

Machine Length	8704 mm	343 in
Wheelbase Length	4266 mm	168 in
Ground Clearance	311 mm	12.25 in
Machine Height (Canopy)	2275 mm	90 in
Machine Height (Crane)	2617 mm	103 in

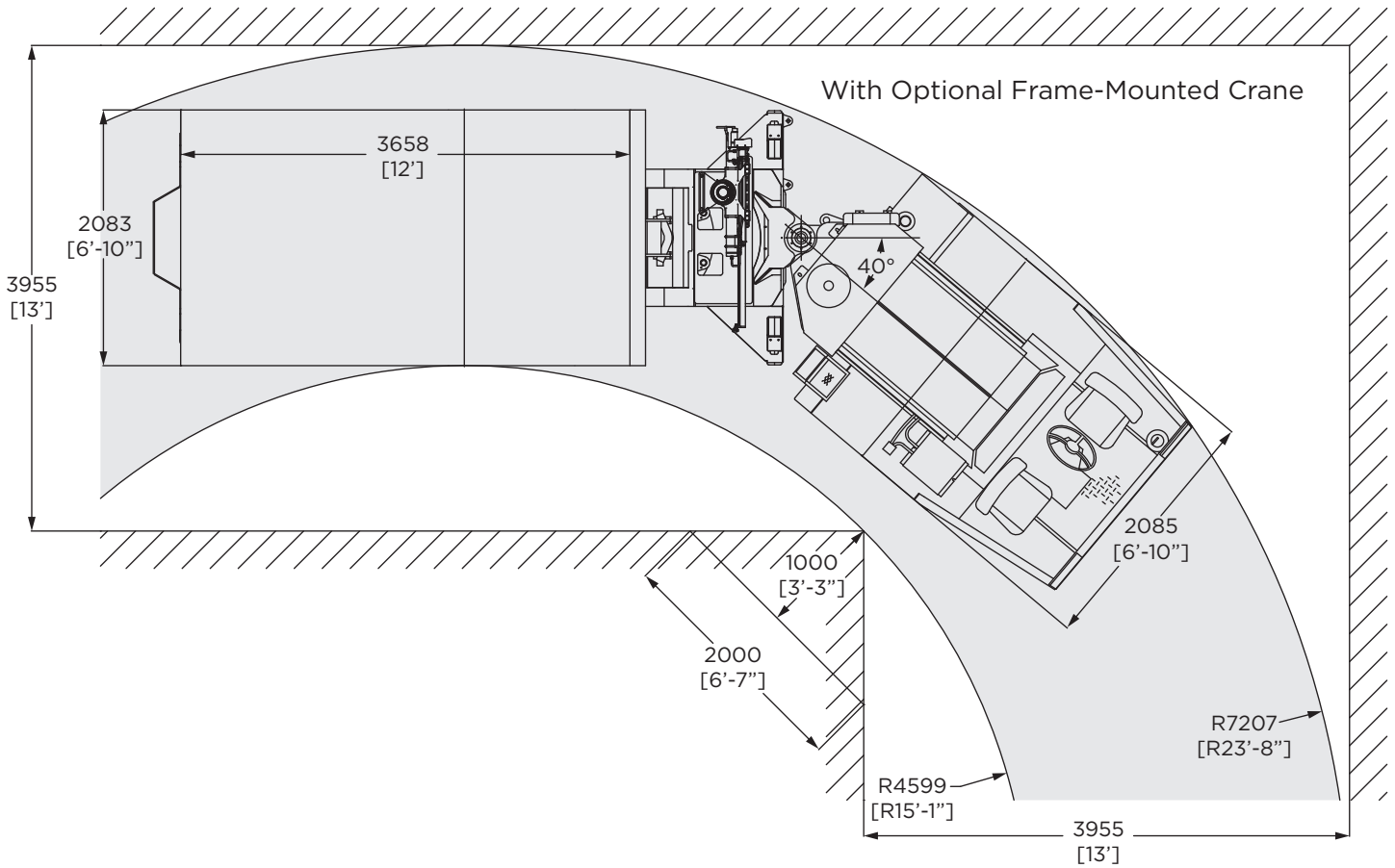

Machine Width	2085 mm	82 in
Inner Turning Radius	4599 mm	181 in
Outer Turning Radius	7207 mm	284 in

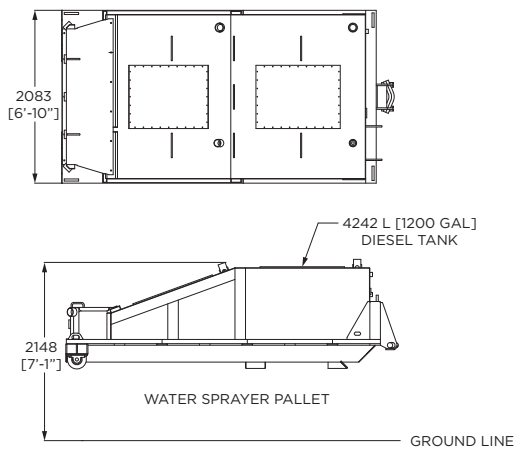
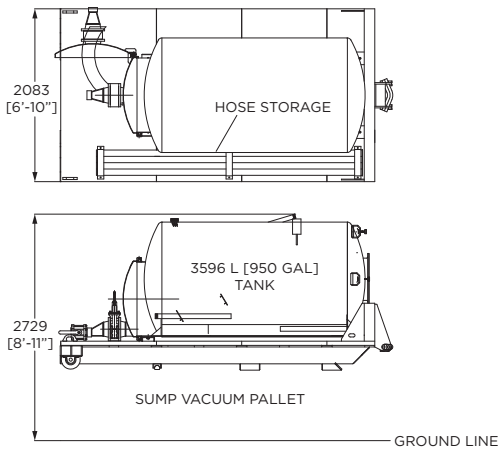
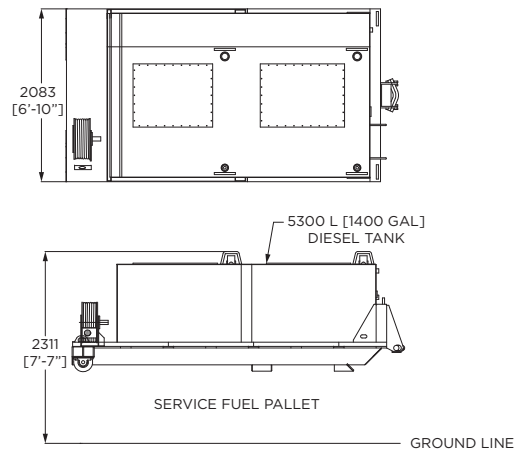
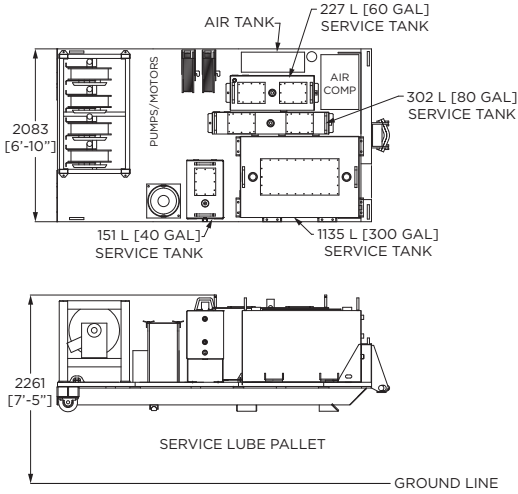
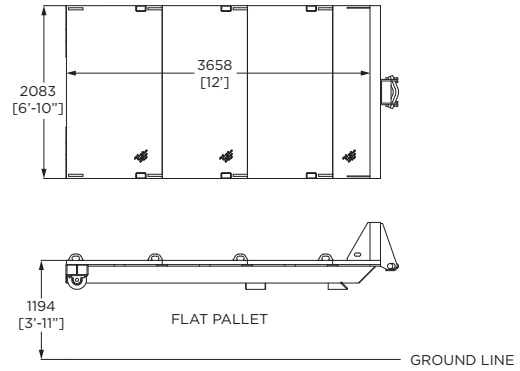
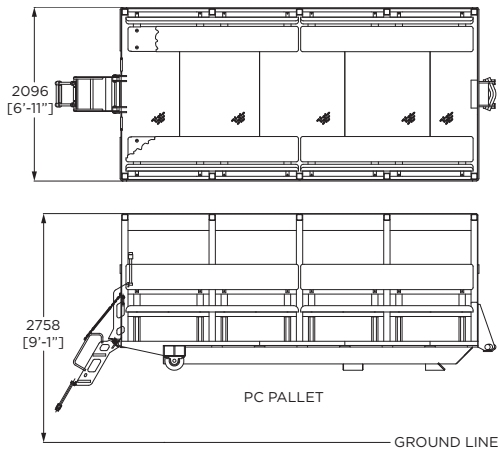

PC Pallet		
Pallet Width	2096 mm	83 in
Pallet Height (loaded on Pallet Handler)	2758 mm	109 in
Capacity	16 persons	

Flat Pallet		
Pallet Width	2083 mm	82 in
Pallet Length	3658 mm	144 in
Pallet Height (loaded on Pallet Handler)	1194 mm	47 in

Service Lube Pallet		
Pallet Width	2083 mm	82 in
Pallet Height (loaded on Pallet Handler)	2261 mm	89 in
Tank #1 Capacity	1135 L	300 gal
Tank #2 Capacity	302 L	80 gal
Tank #3 Capacity	227 L	60 gal
Tank #4 Capacity	151 L	40 gal

Service Fuel Pallet		
Pallet Width	2083 mm	82 in
Pallet Height (loaded on Pallet Handler)	2311 mm	91 in
Tank Capacity	5300 L	1400 gal

Sump Vacuum Pallet		
Pallet Width	2083 mm	82 in
Pallet Height (loaded on Pallet Handler)	2729 mm	107 in
Tank Capacity	3596 L	950 gal

Water Sprayer Pallet		
Pallet Width	2083 mm	82 in
Pallet Height (loaded on Pallet Handler)	2148 mm	85 in
Tank Capacity	4542 L	1200 gal

HIAB 044-1 Crane Coverage

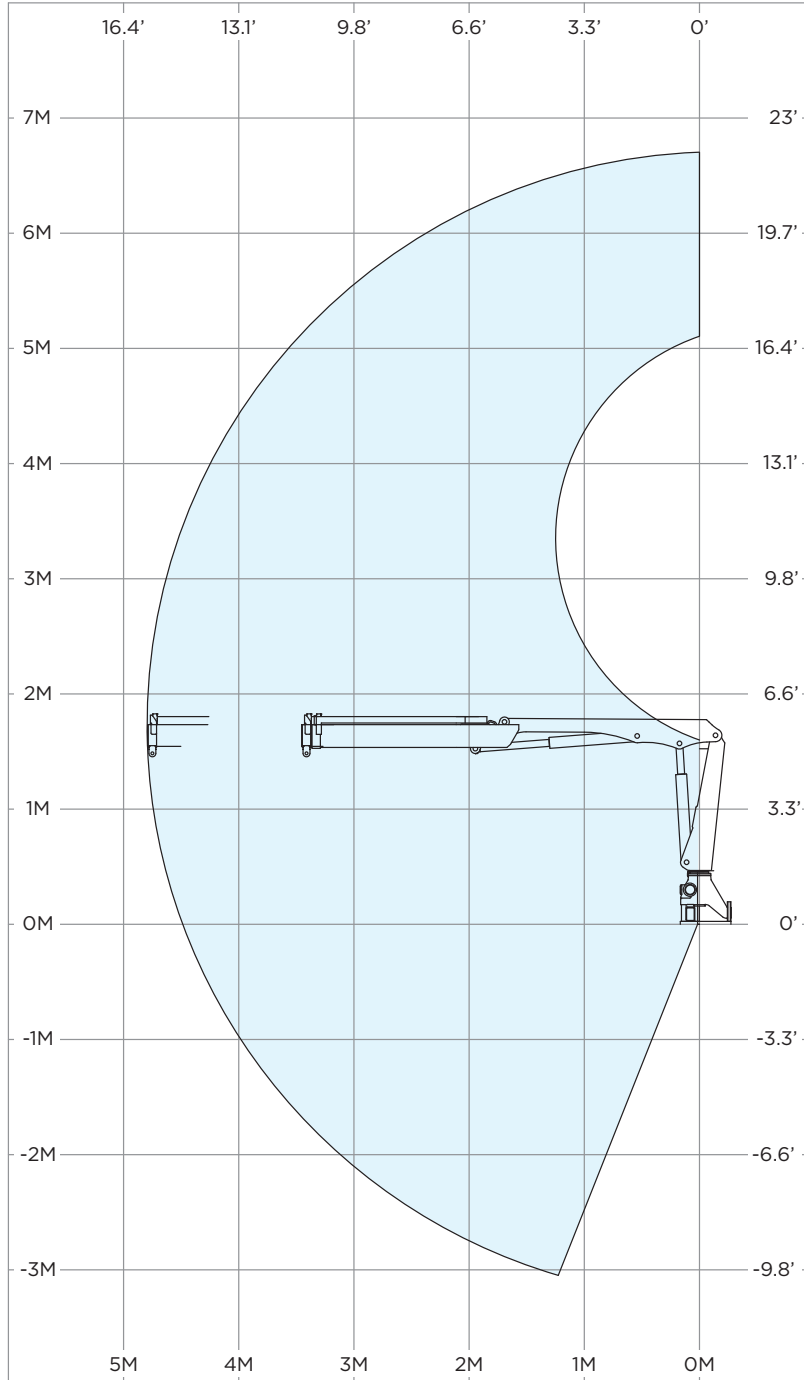

This document shall be considered informational only. All values stated herein are theoretical in nature. Getman reserves the right to make changes to the specification herein at any time and without further notification.